

## Introduction

Owners are responsible for ensuring that the vehicle is regularly serviced at the correct mileage/time intervals as specified in the 'Maintenance Schedules'. The first part of this section deals with regular servicing.

The condition of the tyres is of the utmost importance. Advice about tyre wear and correct usage is given in this section. If in any doubt about the condition of your tyres, contact a Jaguar Dealer.

## Regular Servicing

Each vehicle is given a full 'Pre-Delivery Inspection' to ensure that all systems function correctly and the vehicle meets its specification.

Regular maintenance and servicing is the responsibility of the owner. Jaguar Dealers will be pleased to arrange periodic servicing in accordance with the USA/Mexico '**Passport to Service**' Booklet or Canadian '**Club Jaguar**' Warranty and Benefits Information Booklet. Refer also to section 1: Scheduled Maintenance.

Failure to implement maintenance at the recommended intervals could result in deterioration of vehicle performance and possible infringement of regulations.

## Tyres

Tyres of the correct type and dimensions, with correct cold inflation pressures are an integral part of every vehicle's design. Regular maintenance of tyres contributes not only to safety, but to the designed function of the vehicle. Roadholding, steering and braking are especially vulnerable to incorrectly pressurised, badly fitted or worn tyres.

Tyres of the correct size and type but of different make have widely varying characteristics. It is therefore recommended that Jaguar approved tyres (see Section 6: **Wheel/Tyre Data**) are fitted to all wheels.

Do not interchange tyres from side to side, front to rear or vice versa as tyre wear produces characteristic patterns depending upon their position and, if the position is changed after wear has occurred, the performance of the tyre will be adversely affected.

### Note:

1. On certain models the rear wheel and tyre assemblies will be larger than the front. These larger assemblies must never be fitted to the front of the vehicle.
2. On certain models the tyres specified may be of a directional type. These tyres must be fitted so that when viewed from the side of the vehicle the tyre 'direction of rotation' arrow points in the vehicle direction, when positioned at the top of the tyre.

### Tyre Repair

It is recommended that damaged tyres are discarded and new tyres fitted. They must not be repaired in view of the high performance capability of the vehicle.

## 5-2 Vehicle maintenance

---

### Tyre Use After Vehicle Storage

After a long period of a vehicle standing, tyres may become locally distorted with a flat area. This will cause an uneven ride for a few miles until the tyres have warmed up and the 'flat' rounds off.

However, to reduce the effects of flat-spotting, the tyres of a stored vehicle may be inflated to 44 lb/in<sup>2</sup> (300 kPa).

Refer to Section 6, **Recommended Tyre Pressures** for normal operating pressures.

### Tyre Size, Type, Pressures

The tyre pressures recommended (see Section 6: **Wheel/Tyre Data**) provide optimum ride and handling characteristics for all normal operating conditions. The pressures should be checked, and correctly set, if necessary, once per week. This should be done with the tyres cold. Tyre temperatures and pressures increase when running. Deflating a warm tyre to the recommended pressure will result in under inflation which may be dangerous.

A slight natural pressure loss occurs with time. If this exceeds 2 lb/in<sup>2</sup> (14 kPa) per week, the cause should be investigated and rectified.

It is an offence in many States and certain other countries to drive a vehicle with tyres that are not inflated in accordance with the vehicle's proper use.

A vehicle fitted with winter tread tyres must only be driven at speeds below the figure moulded into the tyre's side wall. If no figure is shown, drive only at moderate speed.

### Tyre Renewal

When renewal of tyres is necessary it is preferable to fit a complete vehicle set. Should either front or rear tyres only show need for renewal, new tyres must be fitted, as axle sets, to replace worn ones.

**Note:** After new tyres have been fitted the wheels need to be dynamically balanced.

The radial ply tyres specified are designed to meet the high speed performance capability of this vehicle.

Only tyres of identical specification as shown in Section 6: **Wheel/Tyre Data** must be fitted. Do not fit tyres with a different tread pattern, size or speed rating.

### Damage

Excessive local distortion can cause the casing of a tyre to fracture and may lead to premature failure. Tyres should be examined especially for cracked walls, exposed cords, etc. Flints and other sharp objects must be removed from the tyre tread; if left in they may work through the cover. Clean off any oil or grease contamination by using a suitable cleaner.

**Caution: Do not use paraffin (kerosene), which has a detrimental effect on rubber.**

## Wear

All tyres fitted as original equipment include tread wear indicators (TWI) in their tread pattern. When the tread has worn to a remaining depth of 0.063 inch (1,6 mm) the indicators appear at the surface as bars which connect the tread pattern across the full width of the tyre.

It is illegal in many States and certain other countries to continue to use tyres after the tread has worn to less than 0.063 inch (1,6 mm) over three quarters of the width and the entire circumference of the tyre.

It should be noted that the properties of many tyres alter progressively with wear. In particular the 'wet grip' and aquaplaning resistance are gradually but substantially reduced. Extra care and speed restriction should therefore be exercised on wet roads as the effective tread depth diminishes.

Incorrect wheel alignment will accelerate tyre wear. Fins on the inner or outer edges of the tread pattern are caused by excessive toe-in or toe-out respectively. As fins may also be caused by high cornering speeds or road camber, it is advantageous to have the cause detected by having the wheel alignment checked.

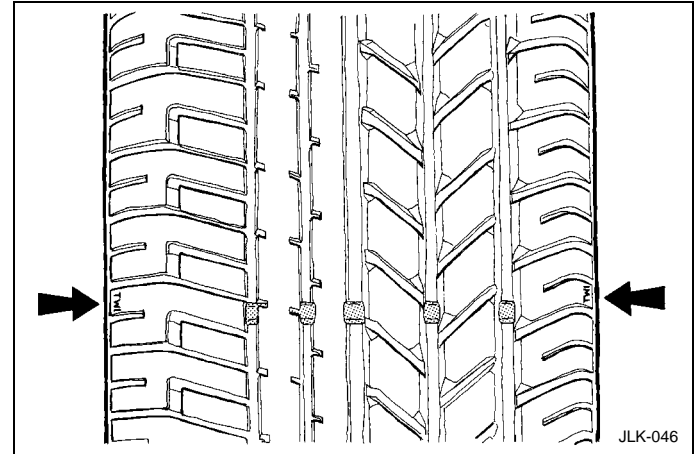

## 5-4 Vehicle maintenance

---

### Snow Chains and Spikes Spiders

Snow chains, of the recommended type, may be fitted **only** when using 17 inch roadwheels with 245/50 ZR17 tyres. Spikes spiders may be fitted up to a maximum of 18 inch diameter roadwheels. Snow chains or spikes spiders must be fitted to the **rear wheels only**. Contact your Jaguar Dealer for details and availability of approved snow chains or spikes spiders.

**Note:** Traction control (if fitted) MUST be switched OFF when using snow chains or spikes spiders.

The maximum speed when using snow chains or spikes spiders is 30 mph (48 km/h).

Remove the snow chains or spikes spiders immediately the roads are clear of snow.

Ensure the fitting instructions supplied with the snow chains or spikes spiders are kept in a safe place, for example, the Vehicle Care literature pack.

### Care of Wheels

The wheels are covered with a protective coating. To prevent corrosion it is essential that this coating is not damaged.

When removing or fitting tyres always advise the tyre fitter to treat the wheels with great care and to only use equipment with spigot or stud hole clamping. The equipment must not have any moving parts which contact the wheel, and tyre levers must not be used.

Always ensure that the wheel nuts are fully seated before finally tightening the nuts in alternate sequence.

## United States Department of Transportation/Uniform Tyre Quality Grades.

The following information relates to the tyre grading system developed by the National Highway Traffic Safety Administration which will grade tyres by tread wear, traction and temperature performance.

### Tread wear

The tread wear grade is a comparative rating based on the wear rate of the tyre when tested under controlled conditions on a specified government test course. For example, a tyre graded 150 would wear one and a half (1½) times as well on the government course as a tyre graded 100. The relative performance of tyres depends upon the actual conditions of their use, however, and may depart significantly from the norm due to variations in driving habits, service practices and differences in road characteristics and climate.

### Traction grades

The traction grades, from the highest to the lowest are AA, A, B and C, and they represent the tyre's ability to stop on wet pavements as measured under controlled conditions on specified government test surface of asphalt and concrete. A tyre marked 'C' may have poor traction performance.



### WARNING:

**The traction grade assigned to this tyre is based on braking (straight ahead) traction tests and does not include cornering (turning) traction.**

### Temperature grades

The temperature grades 'A' (the highest), 'B' and 'C' represent the tyre's resistance to the generation of heat and its ability to dissipate heat when tested under controlled conditions on a specified indoor laboratory test wheel. Sustained high temperature can cause the material of the tyre to degenerate and reduce tyre life, and excessive temperature can lead to sudden tyre failure.

The grade 'C' corresponds to a level of performance which all passenger car tyres must meet under the Federal Motor Vehicle Safety Standard N<sup>o</sup>. 109.

The Grade 'B' and 'A' represent higher levels of performance on the laboratory test wheel than the minimum required by law.



### WARNING:

**The temperature grade for this tyre is established for a tyre that is properly inflated and not overloaded.**

**Excessive speed, under-inflation or excessive loading, either separately or in combination, can cause heat build-up and possible tyre failure.**

## 5-6 Vehicle maintenance

---

### Battery

A low maintenance battery specifically designed for use with this vehicle is fitted in the luggage compartment.

Under normal operating conditions the battery requires minimal maintenance. However, in hot weather conditions it is advisable to check the battery electrolyte levels at regular intervals.



1. **The cell plugs and vent pipe must be in place at all times when the battery is in the vehicle. Failure to fit, or incorrect fitting of these items is potentially hazardous.**
2. **To avoid injury do not use an open flame or cause an electric spark when checking the battery. Hydrogen gas generated by the battery is flammable and may explode.**
3. **Do not connect any 12 volt equipment (for example, a 12 volt lead lamp), directly to the battery terminals. Use the cigar lighter socket for temporarily connecting Jaguar approved accessories.**
4. **Do not let battery acid come into contact with skin or eyes. If you get electrolyte in your eyes or on your skin, immediately rinse with cold water and consult a doctor.**
5. **California Proposition 65: battery posts, terminals and related accessories contain lead and lead compounds. Wash your hands after handling.**

### Caution:

1. **Switch off current before disconnecting battery terminals. Always disconnect the earth terminal first and reconnect last.**
2. **Do not let battery acid come into contact with painted surfaces or fabric.**

The exterior of the battery should be occasionally wiped clean to remove any dirt or grease.

If a new battery is to be fitted, it must be the same type as the original. The use of unapproved batteries is not recommended and could invalidate the vehicle warranty.

### Note:

1. The service life of the battery is dependent on its condition of charge. It must always be sufficiently charged for the battery to last an optimum length of time.
2. We recommend that the battery charge is checked frequently if the vehicle is used mostly for short distance trips, or if it is not used for long periods of time.

### Generator

To prevent damage to the generator, do not run the engine while the battery or any of the charging circuit cables are disconnected.

The generator has polarity sensitive components that may be irreparably damaged if subjected to incorrect polarity. Ensure that the battery earth lead is always connected to the battery negative (-) terminal.

## Check/Top Up Battery Electrolyte

**Note:** In normal climates this must be carried out at least once a year. In hot weather/climates the electrolyte level must be checked at least every three months.

Remove the luggage compartment floor panel and the right-hand side panel. Unscrew the six cell plugs. Check that the electrolyte is level with the plastic level indicator (A). If necessary, top up with distilled water but do not overfill. If illumination is required, use a hand-held flashlight to inspect the electrolyte level. Refit the six cell plugs. Refit the floor panels.

## Battery Charging



**WARNING:**

**Batteries produce combustible gas (hydrogen) when being charged. The battery must be removed from the vehicle before charging commences.**

To disconnect the battery, refer to **Battery Lead Disconnection** on page 5-8.

When charging the battery ensure that the charge voltage is the same as the nominal voltage of the battery.

**Switch off the charger before connecting or disconnecting terminal connections to avoid sparks and short circuits.**

Ensure that the charger positive (+) lead is connected to the positive (+) terminal of the battery and the negative (-) lead is connected to the negative (-) terminal of the battery.

Do not remove or loosen any of the cell plugs when charging the battery.

Check, and if necessary top-up the electrolyte level when the battery is fully charged.

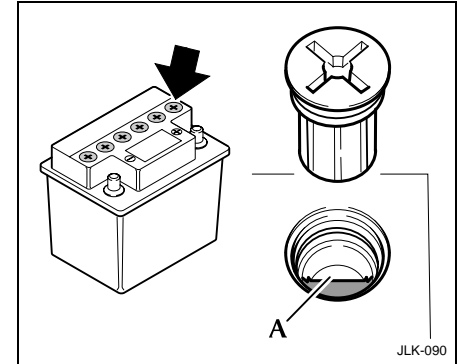

## Clean and Grease Battery Connections

Disconnect the battery leads as detailed in battery disconnection on page 5-8.

Clean the battery posts and coat the post bases with petroleum jelly.

Reconnect the battery leads as detailed in battery connection on page 5-8.

## 5-8 Vehicle maintenance

### Battery Lead Disconnection

**Note:** Upon battery disconnection, both trip computer memories (A and B) will be erased. On reconnection the radio will require recoding and the clock will need to be reset.

#### Caution:

1. Under no circumstances should a battery be disconnected whilst the ignition circuit is live, as permanent damage to the instrument pack may occur.
2. Leave windows partially open if access to the vehicle interior is required (automatic window drop for door opening will not function with battery disconnected).
3. Disconnect the negative lead (earth terminal) first.



#### WARNING:

**California Proposition 65: battery posts, terminals and related accessories contain lead and lead compounds. Wash your hands after handling.**

Remove the luggage compartment floor panel and the right-hand side panel (where fitted).

Unclip the battery positive terminal cover.

Slacken the **negative** lead pinch bolt (10 mm spanner required) and disconnect the **negative** (-) battery lead. Slacken the **positive** lead pinch bolt and disconnect the **positive** (+) battery lead.

### Battery Lead Connection

Whenever either or both battery cables are disconnected, a **minimum of 30 seconds MUST** elapse between disconnection of the first cable and reconnection of the last cable.

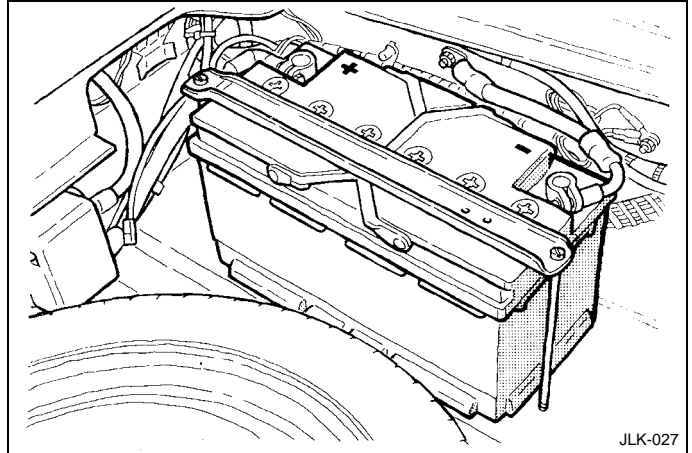

A 'clean' final reconnection must always be made. Should the cable make temporary contact only, wait another 30 seconds before making the final reconnection.

#### Caution: Do not over tighten the pinch bolts.

Connect the **positive** (+) lead, tighten the pinch bolt and clip the positive terminal cover on the battery.

Connect the **negative** (-) lead and tighten the pinch bolt.

Refit the floor panels.

After the battery has been reconnected and the ignition switch is turned to position 'II', the message centre display will initially show an erroneous reading i.e. -----. This will remain until after the bulb check sequence, when the correct recorded mileage will be displayed.

This is a normal function of the instrument pack.



## Battery Lead Connection (continued)

**Note:** After battery disconnection, the door windows need to be reprogrammed to 're-learn' the upper and lower limits of travel. This simple procedure is explained fully in the Driver's Handbook, Section 3.

Reset the clock to the correct time.

The radio cassette player display will indicate 'code'. The radio will not operate until the correct security code has been re-entered. Refer to the Sound System Handbook.

## Bulb Renewal

It is important that only Jaguar bulbs of the type specified on page 5-16 are used when renewing bulbs.

Before renewing bulbs, switch off the ignition and light switches.

### Front Fog Lamp – Bulb Renewal

It is recommended that the front fog lamp bulbs are renewed by a Jaguar Dealer.

### Headlamp – Bulb Renewal

**Caution:** These bulbs are halogen types and will be damaged if touched by hand or contaminated with oil or grease. It is important to use clean gloves or cloth when handling a bulb which is to be used again. A contaminated bulb may be cleaned with methylated spirit before refitting.

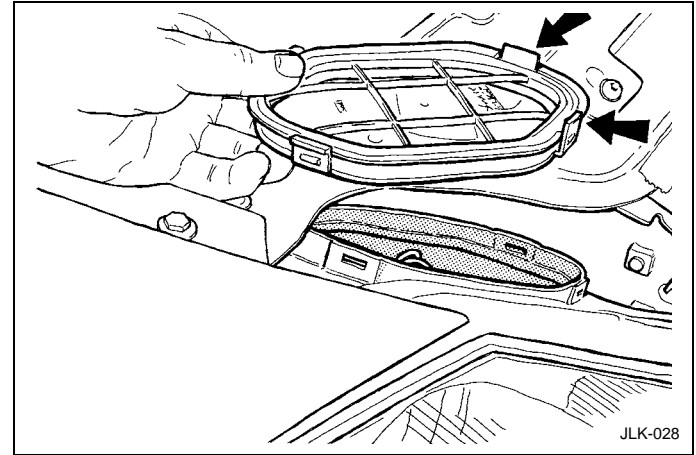

### Main Beam, Front Direction Indicator and Side Light Access

Access to the headlamp unit for main beam, front direction indicator and side light bulb renewal, is through the clear hexagon cap at the rear of the headlamp unit.

Open the hood and remove the hexagon cap by squeezing the two lower clips, arrowed above.

When refitting the hexagon cap make sure the seal is in place.

## 5-10 Vehicle maintenance

To change any of the bulbs shown on this page, first remove the hexagon access cap as described on page 5-9.

### Main Beam – Bulb Renewal (A)

Rotate the bulb holder anticlockwise by a quarter of a turn to remove from the headlamp unit. Lift the plastic spring clips (B) and remove the bulb assembly from the harness connector. Remove the bulb and fit a new one of the correct type, see page 5-16. Refit the bulb assembly to the harness connector. Refit the assembly into the headlamp unit.

### Front Direction Indicator – Bulb Renewal (C)

Turn the direction indicator bulb holder a quarter turn and remove.

Remove the bulb and fit a new one of the correct type, see page 5-16.

### Front Parking (Side) Light – Bulb Renewal (D)

Rotate the bulb holder a quarter turn and remove from the headlamp.

Pull the bulb from the holder and fit a new one of the correct type, see page 5-16.

Reposition the bulb holder in the headlamp unit and rotate a quarter turn.

Refit the hexagon access cap as described on page 5-9.

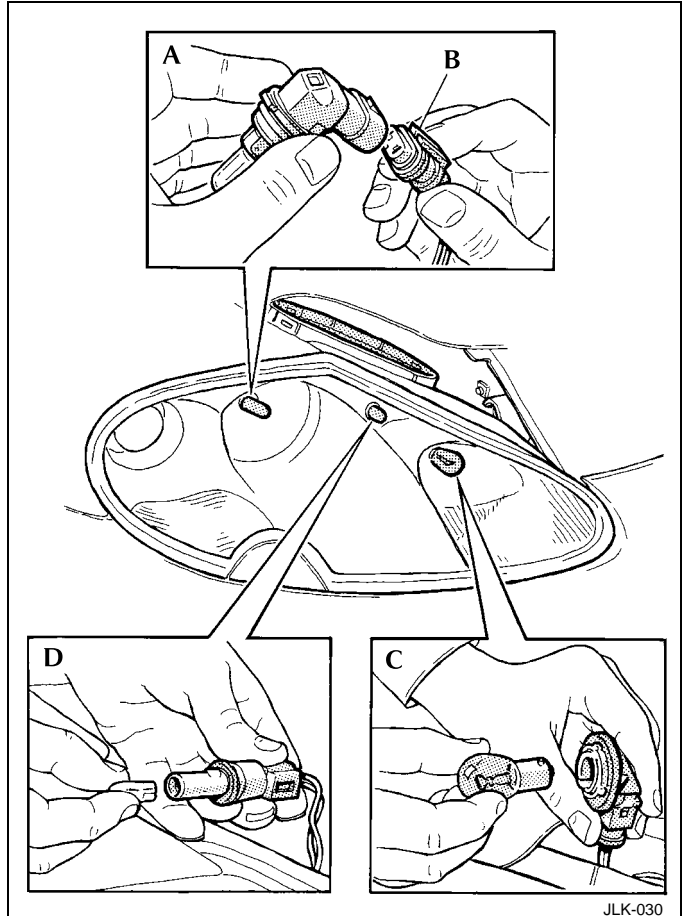

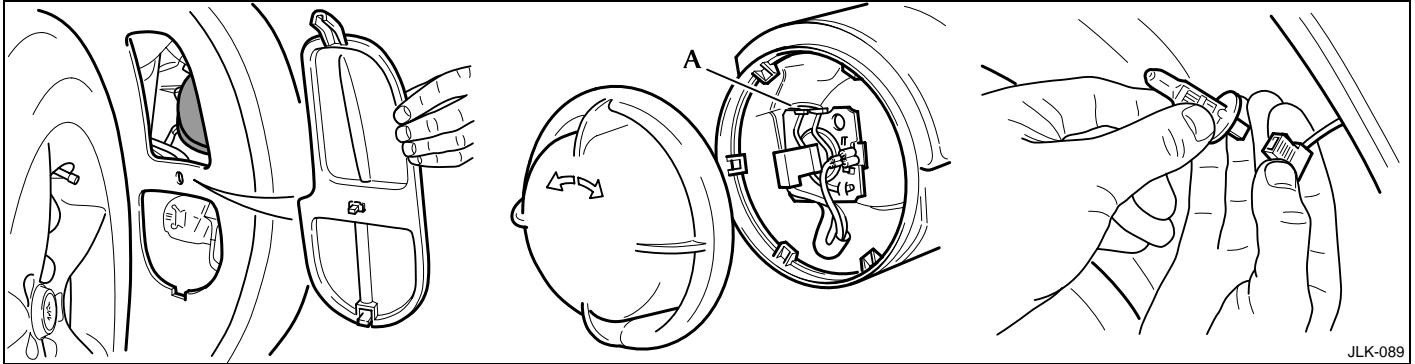

JLK-089

## Dip Beam Bulb Access

Access to the dip beam bulb is as follows:  
Turn the front wheels to allow free access to the wheel arch.

Remove the wheel arch access panel by rotating the centre fastener and lifting the lower retaining clip.

Turn the cap at the back of the dip beam a quarter turn anticlockwise and remove.

When refitting the cap make sure the seal is in place.

## Dip Beam – Bulb Renewal

Push the spring retainer (A) to the right and rearwards to release. Remove the bulb holder.

Remove the bulb and fit a new bulb of the correct type, see page 5-16.

Refit the bulb holder and the spring retainer.

## 5-12 Vehicle maintenance

### Rear Light Assembly -Bulb Renewal

Ensure that the lights and ignition switch are OFF before removing any bulbs. Open the luggage compartment.

Unscrew the two fasteners securing the light assembly cover (top figure). Remove the cover, noting the cover locating pin.

Press the release bar on the electrical connector (centre figure) and carefully pull off the connector. Unscrew the knurled nut securing the bulb carrier and remove the carrier.

The left-hand bulb carrier is shown and the bulbs fitted are:

- Direction indicator (A).
- Reversing light (B).
- Fog light (C).
- Tail light (D).
- Stop and tail light (E).

Remove the faulty bulb and fit a new one of the correct type, as specified on the bulb carrier and the bulb chart (see page 5-16).

Note that 12V, 21W/5W stop/tail bulbs are fitted in positions E and D but the stop light in position D is not used.

Refit the bulb carrier and secure with the knurled nut. Carefully plug in the electrical connector.

To refit the rear cover, insert the cover locating pin, close the cover and secure with the two screw fasteners.

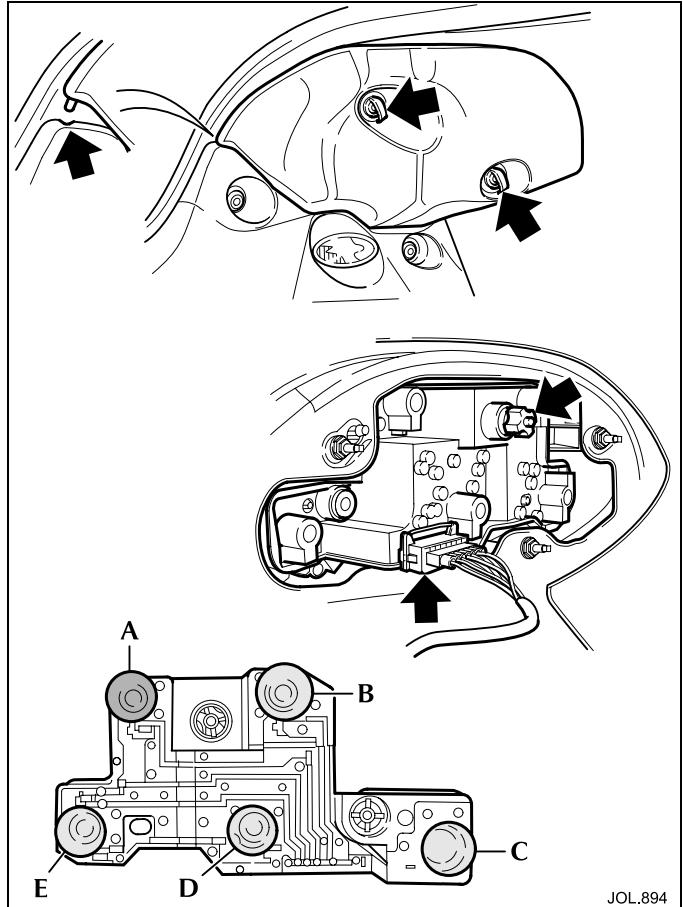

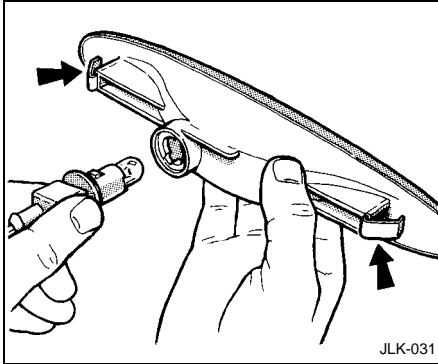

JLK-031

## Side Marker Light – Bulb Renewal

To remove the side marker lenses it is necessary to compress the spring clips at the back of the lens. Access to the rear of the **front** side marker is through the wheel arch access panel.

To access the back of the **rear** side marker It is necessary to reach up behind the bumper cover. Because of the proximity of the exhaust system, make sure the exhaust is cold when renewing the rear side marker bulb.

Twist the bulb holder anti-clockwise and remove. Pull out the bulb and fit a new one of the correct type, see page 5-16.

Refit the bulb holder.

Press the unit into place in the front wing/ bumper cover.

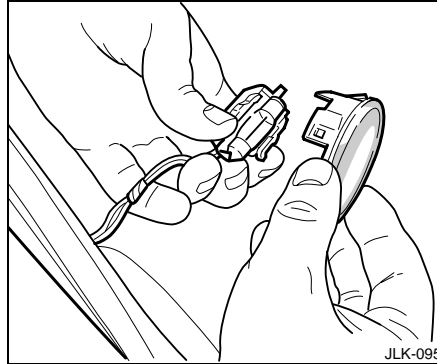

JLK-095

## Luggage Compartment Light – Bulb Renewal

Carefully prise the light unit from the luggage compartment trim panel. Lightly squeeze the clear toggles on both sides of the bulb to remove the lens.

Fit a new bulb of the correct type, see page 5-16.

Refit the lens.

Refit the light unit to the luggage compartment trim panel.

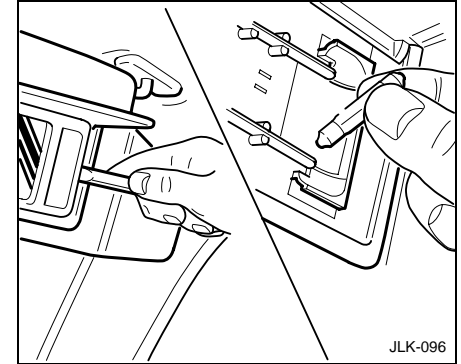

JLK-096

## Sun Visor Vanity Mirror Light – Bulb Renewal

Swing the sun visor down and lift the vanity mirror flap. Using a screwdriver carefully prise the mirror/lens assembly from the sun visor. Remove the bulb from the holder and fit a new one of the correct type, see page 5-16.

Refit the mirror/lens.

## 5-14 Vehicle maintenance

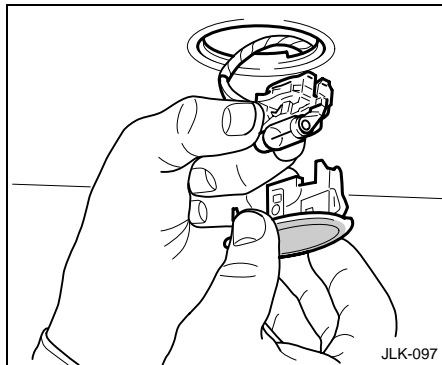

### Interior Roof Light (Coupe Only) – Bulb Renewal

Carefully prise one end of the light unit from the roof and remove. Lightly squeeze the clear toggles on both sides of the bulb to remove the lens.

Remove the bulb and fit a new one of the correct type, see page 5-16.

Refit the lens.

Refit the light unit back into the roof.

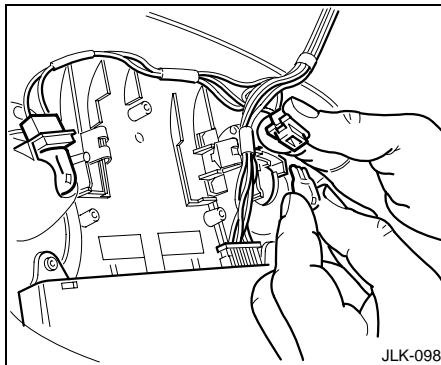

### Roof Console Courtesy and Map Light – Bulb Renewal

Carefully remove the roof console from the trim panel. (The console is a pull/push fit.)

Remove the bulb holder.

Remove the bulb and fit a new one of the correct type, see page 5-16.

Refit the bulb holder.

Refit the roof console by carefully pressing into position in the trim panel.

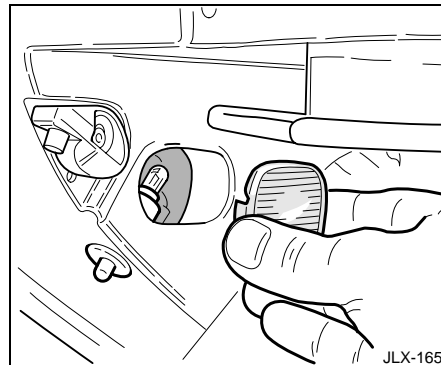

### Glove Box Light – Bulb Renewal

Open the glove box and carefully prise the lens from the left-hand side of the glove box.

Remove the bulb from the bulb holder and fit a new one of the correct type, see page 5-16.

Refit the lens into the glove box.

## Footwell Light – Bulb Renewal

Press the light unit forward against the spring and carefully prise out the edge of the unit to allow its removal.

Remove the bulb holder.

Remove the bulb and fit a new one of the correct type, see page 5-16.

Refit the light unit.

## Door Guard Light – Bulb Renewal

Remove the red/clear lens by inserting a flat blade screwdriver through the access hole at the bottom of the lens, to disengage the clip leg, then slide the lens down.

Remove the bulb and fit a new one of the correct type, see page 5-16.

Refit the lens.

## Number Plate Light – Bulb Renewal

A special tool is required to remove the trim to give access to the number plate light. It is recommended that number plate bulb is renewed by a Jaguar Dealer.

## High Mounted Stop Light – Interior and Exterior – Renewal

Both types of high mounted stop lights have 16 LEDs. Should one or more of these LEDs fail, then the unit may cease to meet legal requirements and must be renewed immediately by a Jaguar Dealer.

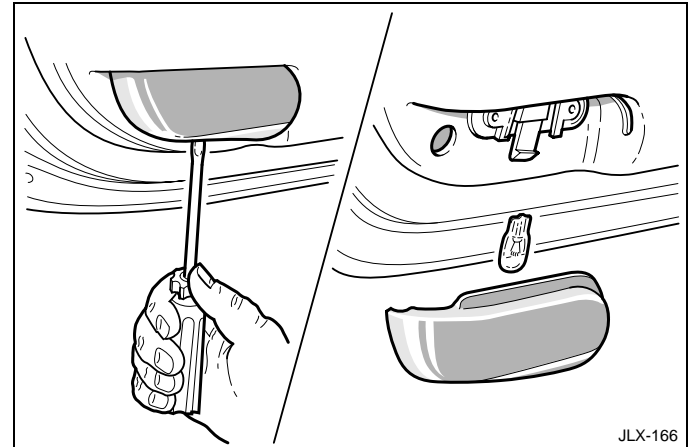
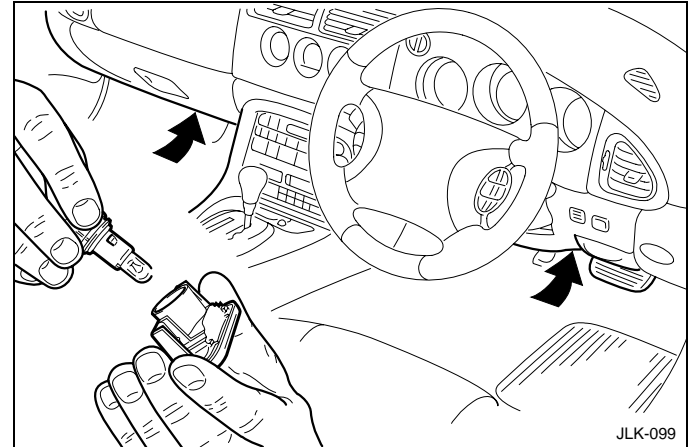

## 5-16 Vehicle maintenance

---

### Bulb Chart

Description	Capacity	Type
Door guard light.	12V 5W	Capless long life.
Side marker light.	12V 5W	Capless long life.
Fog lamp – Front.	12V 55W	Halogen H3 long life.
Fog light – Rear guard.	12V 21W	Bayonet long life.
Footwell light.	12V 5W	Bayonet long life.
Front direction indicator.	12V 21W	Bayonet amber long life.
Front parking (side) light.	12V 5W	Capless long life.
Glovebox light.	12V 4W	Bayonet long life.
Headlamp – dip.	12V 55W	Halogen H1 long life.
Headlamp – Main beam.	12V 60W	Halogen HB3.

Description	Capacity	Type
Luggage compartment light.	12V 5W	Festoon long life.
Number plate light.	12V 5W	Capless long life.
Rear direction indicator.	12V 21W	Bayonet amber long life.
Reverse light.	12V 21W	Bayonet long life.
Roof central courtesy light – Coupe.	12V 5W	Festoon long life.
Roof console map light.	12V 6W	Capless.
Side marker light	12V 5W	Capless long life
Stop/tail lights. (The stop lights in the inner positions are not used.)	12V 21/5W	Bayonet long life.
Sun visor vanity mirror light.	12V 3W	Festoon.



## Windscreen Wiper Blades

Use Jaguar Screen Clean Paste to remove contamination from the windscreen to ensure effective wiping or if smearing or juddering becomes evident. A more aggressive cleaning agent may be required to remove stubborn contamination. Contact a Jaguar Dealer for advice.

Wash the wiper blades with a mild detergent solution.

Renew the wiper blades before and after each winter, or more often if required.

**Note:** The wiper blade rubber inserts will be renewed at every service interval except for the 40,000 mile (64 000 kilometre) interval when the wiper blades are renewed (chargeable to customer).

### Windscreen Wiper Blades – Inspect, Clean and Renew

Lift the wiper blade clear of the windscreen and wipe the blade with a clean, soft cloth moistened with water to which a mild liquid detergent has been added.

Inspect the wiper blade, and if there any signs of wear or damage; renew the blade.

### Renewing Windscreen Wiper Blades

Move the wiper arm away from the windscreen, squeeze the retaining clip and withdraw the wiper blade from the arm.

After fitting the new blade, check that it is held firmly.

Re-position the wiper arm and blade on the windscreen.

The wiper blades are specifically designed for Jaguar and no other type of blade will give the correct result.

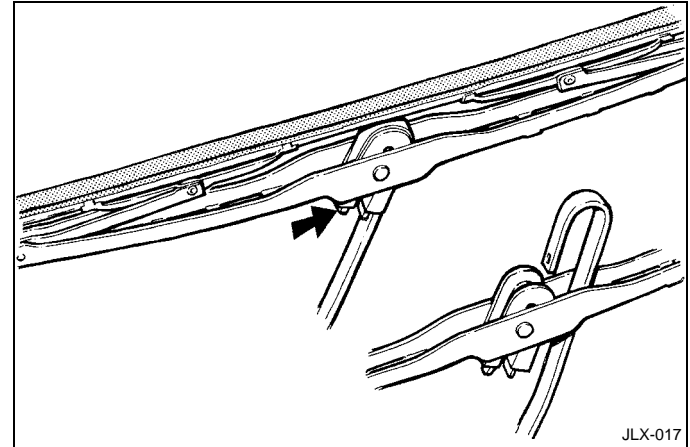

JLX-017

## 5-18 Vehicle maintenance

### Windscreen Washers

The windscreen washer tubes and nozzles are mounted on the wiper arms to apply the washer fluid directly to the windscreen.

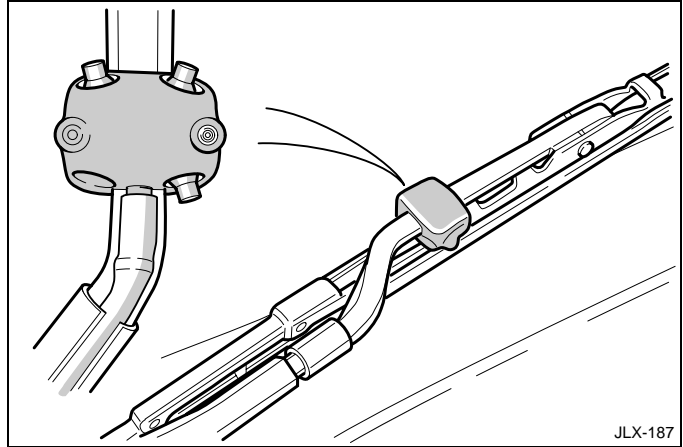

### Powerwash System

**Note:** The headlamp washer jets are factory set. Should they require further adjustment consult your Jaguar Dealer.

